

# Uncertainty Determinants of Corporate Liquidity\*

Christopher F Baum  
Boston College

Mustafa Caglayan  
University of Glasgow

Andreas Stephan  
European University Viadrina, DIW Berlin

Oleksandr Talavera  
DIW Berlin

18th January 2006

---

\*We gratefully acknowledge comments and helpful suggestions by Fabio Schiantarelli and Yuriy Gorodnichenko. An earlier version of this paper appears as Chapter 3 of Talavera's Ph.D. dissertation at European University Viadrina. The standard disclaimer applies. Corresponding author: Oleksandr Talavera, tel. (+49) (0)30 89789 407, fax. (+49) (0)30 89789 104, e-mail: otalavera@diw.de, mailing address: Königin-Luise-Str. 5, 14195 Berlin, Germany.

## UNCERTAINTY DETERMINANTS OF CORPORATE LIQUIDITY

### **Abstract**

This paper investigates the link between the optimal level of non-financial firms' liquid assets and uncertainty. We develop a partial equilibrium model of precautionary demand for liquid assets showing that firms change their liquidity ratio in response to changes in either macroeconomic or idiosyncratic uncertainty. We test this proposition using a panel of non-financial US firms drawn from the COMPUSTAT quarterly database covering the period 1993–2002. The results indicate that firms increase their liquidity ratios when macroeconomic uncertainty or idiosyncratic uncertainty increases.

Keywords: liquidity, uncertainty, non-financial firms, dynamic panel data.

JEL classification: C23, D8, D92, G32.

# 1 Introduction

“As a result of the foregoing, Honda’s consolidated cash and cash equivalents amounted to ¥547.4 billion as of March 31, 2003, a net decrease of ¥62.0 billion from a year ago. ... Honda’s general policy is to provide amounts necessary for future capital expenditures from funds generated from operations. With the current levels of cash and cash equivalents and other liquid assets, as well as credit lines with banks, Honda believes that it maintains a sufficient level of liquidity.”<sup>1</sup>

“Standard & Poor’s said those reserves have declined severely over the last year and blamed the drain, in part, on Schrempp’s massive spending spree, which included taking a 34 percent stake in debt-ridden Japanese automaker Mitsubishi Motors. According to an article in Newsweek magazine, DaimlerChrysler’s cash reserves – a cushion against any economic turndown — will dwindle to \$ 2 billion by the end of the year, down 78 percent from two years ago. That compares with cash reserves of more than \$13 billion at rivals General Motors and Ford, the magazine said.”<sup>2</sup>

Why should a company maintain considerable amounts of cash, as in Honda’s case? Why is a decline in cash reserves problematic as in Daimler-Chrysler’s case? What determines the optimal level of non-financial firms’

---

<sup>1</sup>Citation. <http://world.honda.com/investors/annualreport/2003/17.html>

<sup>2</sup>Citation. <http://www.detnews.com/2000/autos/0012/04/-157334.htm>

liquidity? In the seminal paper of Modigliani and Miller (1958) cash is considered as a zero net present value investment. There are no benefits from holding cash in a world of perfect capital markets lacking information asymmetries, transaction costs or taxes. Firms undertake all positive NPV projects regardless of their level of liquidity.<sup>3</sup>

However, due to the presence of market frictions, we generally observe that there is great variation in liquidity ratios among different types of firms according to their size, industry and degree of financial leverage. For instance, several studies suggest that for liquidity constrained firms, liquid asset holdings are positively correlated with proxies for the severity of agency problems. Myers and Majluf (1984) argue that firms facing information asymmetry-induced financial constraints are likely to accumulate cash holdings. Kim and Sherman (1998) indicate that firms increase investment in liquid assets in response to increase in the cost of external financing, the variance of future cash flows or the return on future investment opportunities.<sup>4</sup> Harford (1999) argues that corporations with excessive cash holdings are less likely to be takeover targets. Almeida, Campello, and Weisbach (2004) develop a liquidity demand model where firms have access to investment opportunities but cannot finance them.

---

<sup>3</sup>Keynes (1936) suggests that firms hold liquid assets to reduce transaction costs and to meet unexpected contingencies as a buffer. This cash buffer allows the company to maintain the ability to invest when the company does not have sufficient current cash flows to meet investment demands.

<sup>4</sup>See also Opler, Pinkowitz, Stulz, and Williamson (1999), Mills, Morling, and Tease (1994) and Bruinshoofd (2003).

We aim to contribute to the literature on corporate liquidity by considering an additional factor which may have important effects on firms' cash management behavior: the uncertainty they face in terms of both macroeconomic conditions and idiosyncratic risks. In explaining the role of macroeconomic uncertainty on cash holding behavior, Baum, Caglayan, Ozkan, and Talavera (2006) develop a static model of cash management under uncertainty with a signal extraction mechanism. In their empirical investigation, they find that firms behave more homogeneously in response to increases in macroeconomic uncertainty.<sup>5</sup> However, their model implies predictable variations in the *cross-sectional distribution* of corporate cash holdings and does not make predictions about the individual firm's optimal *level* of liquidity. Furthermore, they do not consider the impact of idiosyncratic uncertainty on the firm's cash holdings.

In this paper, we complement Baum, Caglayan, Ozkan, and Talavera (2006) by investigating the impact of macroeconomic uncertainty as well as idiosyncratic uncertainty on the cash holding behavior of non-financial firms. We provide a theoretical and empirical investigation of the firm's decision to hold liquid assets. Our theoretical model formalizes the individual firm's precautionary demand for cash and assumes that the firm maximizes its value by investing in capital goods and holding cash to offset an adverse cash flow shock. The optimal level of cash holdings is derived as a function of expected return on investment, the expected interest rate on loans, the finite bounds of their cash flow distribution, the probability of getting a loan and their ini-

---

<sup>5</sup>In a recent paper Bo and Lensink (2005) suggests that presence of uncertainty factors changes the structural parameters of the Q-model of investment.

tial resources. We then parameterize optimal cash holdings and turn to the data to see if there is empirical support for the predictions of the model that managers change levels of liquidity in response to changes in both macroeconomic and idiosyncratic uncertainty. To do that, we match firm-specific data with information on the state of the macroeconomic environment, filling the gap in existing research by investigating the roles of both macroeconomic and idiosyncratic measures of uncertainty on firms' cash holdings.

To test the model's predictions, we apply the System GMM estimator (Blundell and Bond, 1998) to a panel of US non-financial firms obtained from the quarterly COMPUSTAT database over the 1993–2002 period. After screening procedures our data include more than 30,000 manufacturing firm-quarter observations, with 700 firms per quarter. Since the impact of uncertainty may differ across categories of firms, we also consider five sample splits. Our main findings can be summarized as follows. We find strong evidence of a positive association between the optimal level of liquidity and macroeconomic uncertainty as proxied by the conditional variance of inflation. US companies also increase their liquidity ratios when idiosyncratic uncertainty increases. Results obtained from sample splits confirm findings from earlier research that firm-specific characteristics are important determinants of cash-holding policy.<sup>6</sup>

The remainder of the paper is organized as follows. Section 2 discusses the theoretical model of non-financial firms' precautionary demand for liquid assets. Section 3 describes our data and empirical results. Finally, Section 4

---

<sup>6</sup>For instance, see Ozkan and Ozkan (2004) and the references therein.

concludes.

## 2 Theoretical Model

### 2.1 Model Setup

We develop a two period cash buffer-stock model which describes how the firm's manager should vary the optimal level of liquid assets in response to macroeconomic and/or idiosyncratic uncertainty. We assume that the manager maximizes the expected value of the firm.

At time  $t$  the firm has initial resources  $W_{t-1}$  to be distributed between capital investment ( $I_t$ ) and cash holdings ( $C_t$ ). Cash holdings may include not only cash itself but also low-yield highly liquid assets such as Treasury bills. For simplicity, the firm does not finance any other activities. Investment is expected to earn a gross return in time  $t + 1$ , denoted  $E[R]_{t+1}$ .<sup>7</sup> Liquid asset holdings,  $C_t$ , are required to guard against a negative cash-flow shock.<sup>8</sup> Prior to period  $t + 1$  the firm faces a random cash-flow shock  $\psi_t$ , distributed according to a symmetric triangular distribution with mean zero where  $\psi_t \in [-H_t, H_t]$ .<sup>9</sup> Here  $H_t$  can be interpreted as a measure of uncer-

---

<sup>7</sup>For simplicity we assume that distribution of returns is independent from all other variables' distributions.

<sup>8</sup>The model ignores the transaction motive for holding cash, and the optimal amount of liquid assets is zero in the absence of costly external financing.

<sup>9</sup>The triangular distribution is chosen as an approximation to the normal distribution, which does not have a closed-form solution.

tainty faced by the firm's managers.

There are three possible cases to consider, distinguished by a second subscript on each variable. They are graphically depicted in Appendix B. First, the firm can experience a positive cash-flow shock that occurs with probability  $p_1$  and has conditional expectation  $\psi_{t,1}$ . This corresponds to the right half of the figure.

$$\begin{aligned} p_1 &= \Pr(\psi_t > 0) = 1/2 \\ \psi_{t,1} &= E(\psi_t | \psi_t > 0) = H_t \left(1 - \frac{\sqrt{2}}{2}\right) \end{aligned}$$

The firm's value in this case is

$$W_{t+1,1} = I_t E[R]_{t+1} + C_t + \psi_{t,1} = I_t E[R]_{t+1} + C_t + H_t \left(1 - \frac{\sqrt{2}}{2}\right) \quad (1)$$

Second, the firm could be exposed to a negative cash-flow shock yet may have enough liquid assets to meet it. In the figure, this corresponds to a cash flow shock between  $-C$  and 0. This shock occurs with probability  $p_2$  and has conditional expectation  $\psi_{t,2}$ :

$$\begin{aligned} p_2 &= \Pr(0 > \psi_t > -C_t) = \frac{1}{2} \frac{C_t(2H_t - C_t)}{H_t^2} \\ \psi_{t,2} &= E(\psi_t | 0 > \psi_t > -C_t) = -C_t \left(1 - \frac{\sqrt{2}}{2}\right) \end{aligned}$$

The value of the firm in the case when  $-C_t < \psi_t < 0$  is equal to

$$W_{t+1,2} = I_t E[R]_{t+1} + C_t + \psi_{t,2} = I_t E[R]_{t+1} + C_t \frac{\sqrt{2}}{2} \quad (2)$$

Finally, the size of the negative shock could exceed the available liquid assets of the firm. This event occurs with probability  $p_3$  and has conditional



expectation  $\psi_{t,3}$ :

$$p_3 = \Pr(-C_t > \psi_t) = \frac{H_t^2 - 2H_t C_t + C_t^2}{2H_t^2}$$

$$\psi_{t,3} = E(\psi_t | -C_t > \psi_t) = -H_t + \frac{\sqrt{2}}{2}(H_t - C_t)$$

In this case the firm must seek external finance and borrow  $-(\psi_t + C_t)$  at the gross rate  $X_t$ . However, there is a probability  $s_t \in [0, 1]$  that the firm will be extended sufficient credit to prevent negative net worth. This implies that with probability  $(1 - s_t)$  the firm declares bankruptcy and its value at time  $t + 1$  is zero.<sup>10</sup> In the figure, this corresponds to a cash-flow shock between  $-H$  and  $-C$ . For simplicity we assume that the probability of being granted sufficient credit is independent of the distribution of cash-flow shocks. The value of the firm in the last case is equal to

$$W_{t+1,3} = s_t (I_t E[R]_{t+1} + C_t + \psi_{t,3} + X_t(\psi_{t,3} + C_t)) \quad (3)$$

$$= s_t \left[ I_t E[R]_{t+1} - (1 + X_t)(H_t - C_t) \left( 1 - \frac{\sqrt{2}}{2} \right) \right]$$

Given the three possible cases, the manager's objective is to maximize the expected value of the firm in period  $t + 1$ . Defining investment as  $I_t = W_{t-1} - C_t$ , the manager's problem can be written as

$$\max_{C_t} (E(W_{t+1})) = \max_{C_t} \left( p_1 W_{t+1,1} + p_2 W_{t+1,2} + p_3 W_{t+1,3} \right) \quad (4)$$

$$= \max_{C_t} \left( \frac{1}{2} \left( (W_{t-1} - C_t) E[R]_{t+1} + C_t + H_t \left( 1 - \frac{\sqrt{2}}{2} \right) \right) \right)$$

$$+ \frac{1}{2} \frac{C_t(2H_t - C_t)}{H_t^2} \left( (W_{t-1} - C_t) E[R]_{t+1} + C_t \frac{\sqrt{2}}{2} \right)$$

---

<sup>10</sup>We ignore the liquidation value of the firm's real assets, which can be assumed seized by creditors.

$$+ \frac{(H_t - C_t)^2 s_t}{2H_t^2} \left( (W_{t-1} - C_t)E[R]_{t+1} - (1 + X_t)(H_t - C_t) \left( 1 - \frac{\sqrt{2}}{2} \right) \right)$$

where  $C_t$  is the only choice variable. Hence, maximizing equation (4) with respect to  $C_t$ , the optimal level of cash can be expressed as<sup>11,12</sup>

$$C_t = \frac{1}{3} \frac{2.83H_t - 2.00(1 - s_t)(W_{t-1} + 2H_t)E[R]_{t+1} - 1.76s_tH_t(X_t + 1) + \sqrt{D}}{1.41 - 2.0E[R]_{t+1}(1 - s_t) - 0.59s_t(X_t + 1)} \quad (5)$$

Note that equation (5) is non-linear. Hence, to test if the model will receive support from the data, we linearize it around the steady state equilibrium:

$$\hat{C}_t = \alpha_1 \widehat{W}_{t-1} + \alpha_2 \widehat{R}_{t+1} + \alpha_3 \widehat{H}_t + \alpha_4 \widehat{X}_t + \alpha_5 \hat{s}_t \quad (6)$$

where the coefficients  $\alpha_1 - \alpha_5$  are functions of the model's parameters. The expected signs of the coefficients are discussed in the following subsection.

## 2.2 Model solution

The analytical solution for the firm's optimal cash holdings is a nonlinear function of initial resources,  $W_{t-1}$ ; the expected gross return on investment,  $E[R]_{t+1}$ ; the gross interest rate for borrowing,  $X_t$ ; the bounds of the triangular distribution of cash shocks,  $H_t$  and  $s_t$ , the probability of acquiring

---

<sup>11</sup>Given its quadratic structure, there are two possible solutions to the optimization problem. We work with the solution that implies non-negative cash holdings, as the other solution has no economic meaning.

<sup>12</sup> $D$  is a function  $f(E[R]_{t+1}, X_t, s_t, H_t, W_{t-1}) : D = 33.17s_tH_t^2E[R]_{t+1} - 6s_tX_tH_t^2 + 5.66W_{t-1}H_tE[R]_{t+1} + 8s_t(2 - s_t)W_{t-1}H_tE[R]_{t+1}^2 + (7.03s_tX_t + 28)H_t^2E[R]_{t+1} + (16.49 - 6s_t)H_t^2 + 28E[R]_{t+1}^2H_t^2 + 4E[R]_{t+1}^2W_{t-1}^2 - 43.11E[R]_{t+1}H_t^2 + 4s_t^2E[R]_{t+1}^2W_{t-1}^2 - 8s_tE[R]_{t+1}^2W_{t-1}^2 + 4s_t^2E[R]_{t+1}^2H_t^2 - 32s_tE[R]_{t+1}^2H_t^2 - 8E[R]_{t+1}^2H_tW_{t-1} - 5.66s_tE[R]_{t+1}W_{t-1}H_t$ .

sufficient credit when bankruptcy threatens. Hence the implicit solution is a complicated function of the model's parameters, for which we cannot obtain comparative static results. To address this problem, we resort to graphical analysis to determine the signs of  $\alpha$ , the parameters in equation (6).

Figure 1 presents the relationship among optimal cash holdings, the gross interest rate for external borrowing and the bounds of the cash-flow shock distribution which captures the degree of uncertainty faced by the firm. The figure is plotted setting initial resources  $W_{t-1} = 30$  and gross returns  $E[R]_{t+1} = 1.3$  for two different probabilities of raising external funds:  $s_t = 0$  and  $s_t = 1$ . In the first panel ( $s_t = 0$ ), when the firm is subjected to a relatively large negative shock it declares bankruptcy with certainty. When  $s_t = 1$  the firm receives external financing with probability one, as depicted in the second panel. If no external financing is available ( $s_t = 0$ ), cash holdings are high and insensitive to the gross interest rate ( $X_t$ ):  $X_t$  is irrelevant to the firm. The firm always holds more cash regardless of the cost of external financing to guard against the need for external funds. However, if the firm can always acquire external financing, cash holdings are sensitive to the cost of funds. In this case, the firm prefers to hold less cash when funds can be acquired cheaply in comparison to the case where it is more expensive. We also note that the level of cash holdings increases as the bounds of the distribution of cash shocks  $H_t$  increases, raising the magnitude of expected cash flow shocks.

In Figure 2, we depict the impact of expected returns and changes in the bounds of the cash-flow shock on the cash holding behavior of the firm. The figure is drawn setting the gross interest rate for external borrowing,  $X_t = 1.3$

and initial resources  $W_{t-1} = 30$  while allowing the probability of raising funds to take the values  $s_t = 0$  and  $s_t = 0.5$ . In this case the optimal level of cash holdings decreases as the expected return on investment  $E[R]_{t+1}$ —the opportunity cost of holding liquid assets—increases. An increase in expected returns induces the manager to channel funds towards profitable investment opportunities, *ceteris paribus*. Furthermore, cash holdings are more sensitive to changes in expected returns when  $s_t = 0.5$  compared to  $s_t = 0$ . However, the impact of a change in the bounds of the cash flow shock distribution is more complicated. When expected returns are low cash holdings increase as the bounds of the cash-flow shock distribution widen. However, when expected return on investment is much higher optimal cash holdings first increase in response to an increase of the bounds of the cash-flow shock distribution and then decrease. Thus, cash holdings exhibit a complex non-linear relationship to uncertainty in the face of changes in expected returns.

In Figure 3, we present the relationship among cash holdings,  $C_t$ , the bounds of the cash-flow shock distribution  $H_t$  and the probability of acquiring sufficient credit when threatened with bankruptcy,  $s_t$ . We plot the figure setting initial resources  $W_{t-1} = 30$  and the gross returns to  $R_{t+1} = 1.3$  while the gross interest rate for external loans is set to  $X_t = 1.3$  or  $X_t = 1.6$ . Notice that cash holdings decrease in response to an increase in the probability of getting a loan (a higher  $s_t$ ). With better odds of external financing, firms are likely to hold less cash, *ceteris paribus*. However, when the costs of external financing are high, cash holdings are less sensitive to the probability of acquiring external financing.

Finally, Figure 4 describes the relationship among cash holdings, initial

resources and the bounds of the cash flow shock distribution. This figure is constructed setting the gross return  $E[R]_{t+1} = 1.3$  and the gross interest rate on external borrowing to  $X_t = 1.3$  while we allow the probability of accessing external funds  $s_t$  to equal 0 or 0.5 as in the earlier cases. Here we observe that a firm with higher initial resources will hold more cash. Moreover, as the bounds of the distribution of cash-flow shocks widen, the firm tends to increase its cash holdings due to the precautionary motive.

Given our interpretations of the graphical analysis, our theoretical model predicts positive signs for  $\alpha_1$  (initial resources) and  $\alpha_4$  (interest rate on external borrowing) and negative signs for  $\alpha_2$  (return on investment) and  $\alpha_5$  (probability of being granted sufficient credit). The sign of  $\alpha_3$  (bounds of the cash-flow shock distribution) depends on the levels of the firm's variables.

### 2.3 Parameterization

In order to find out whether or not the data will support the theoretical model, we must parameterize the coefficients associated with the variables in our model. First consider the firm's expected returns. We assume that the firm maximizes profit, defined as

$$\Pi(K_t, L_t) = P(Y_t)Y_t - w_t L_t - f_t$$

where  $P(Y_t)$  is an inverse demand function,  $f_t$  represents fixed costs,  $L_t$  is labor and  $w_t$  is wages. The firm produces output  $Y$  given by the production function  $F(K_t, L_t)$ .

Expected return on investment  $E[R]_{t+1}$  is equal to the expected marginal profit of capital, which is the contribution of the marginal unit of capital to

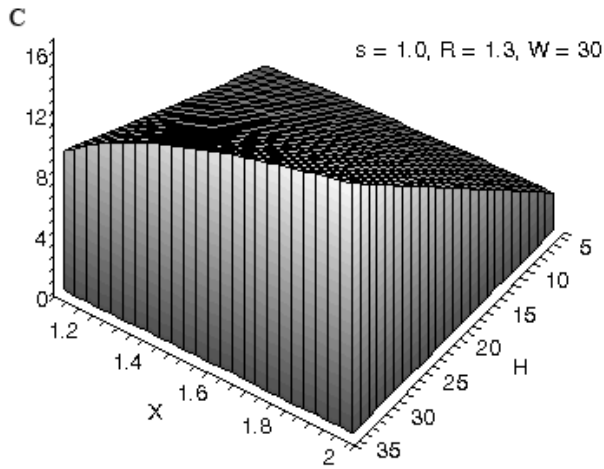
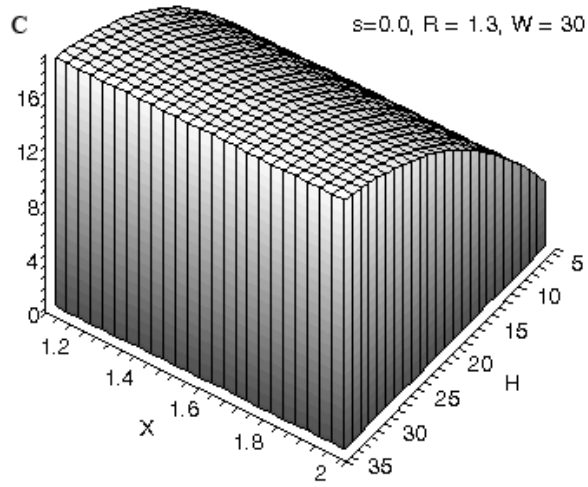

Figure 1: Plot of  $C_t$  against  $X_t$  and  $H_t$  ( $s_t = 0$  and  $s_t = 1, W_{t-1} = 30, E[R]_{t+1} = 1.3$ )

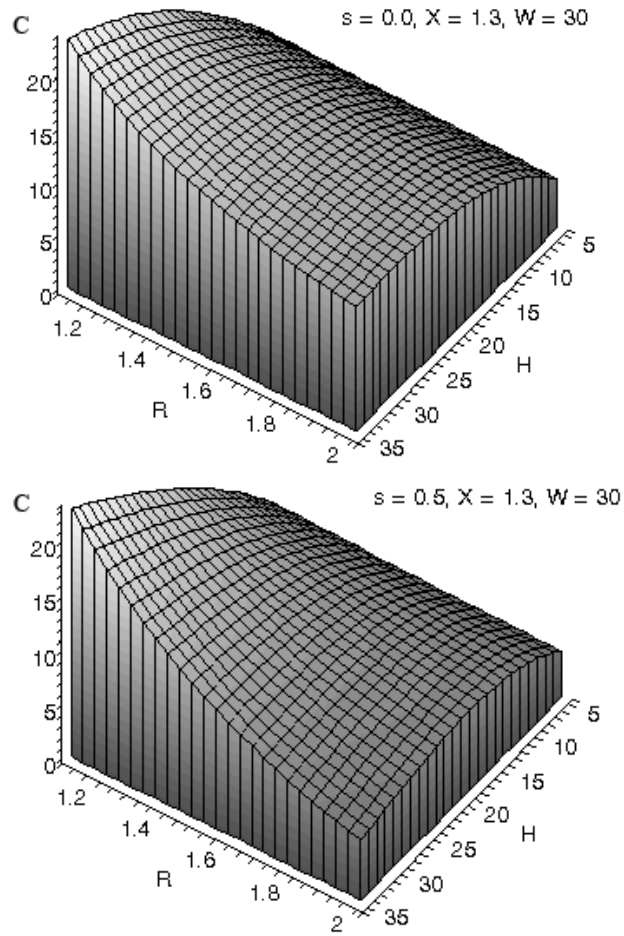

Figure 2: Plot of  $C_t$  against  $E[R]_{t+1}$  and  $H_t$  ( $s_t = 0$  and  $s_t = 0.5, W_{t-1} = 30, X_t = 1.3$ )

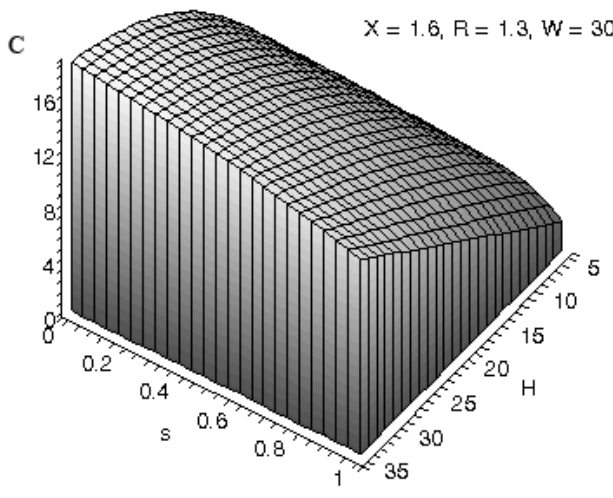
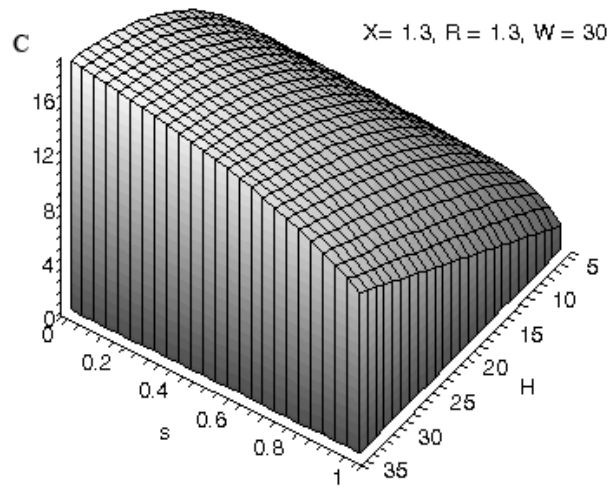

Figure 3: Plot of  $C_t$  against  $s_t$  and  $H_t$  ( $X_t = 1.3$  and  $X_t = 1.6, W_{t-1} = 30, E[R]_{t+1} = 1.3$ )



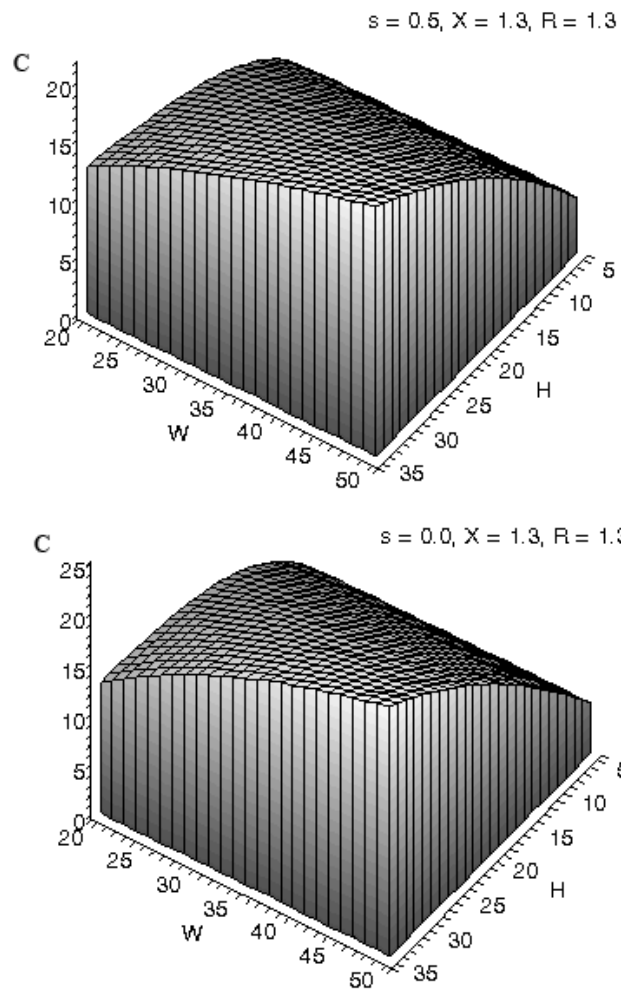

Figure 4: Plot of  $C_t$  against  $W_{t-1}$  and  $H_t$  ( $s_t = 0$  and  $s_t = 0.5$ ,  $E[R]_{t+1} = 1.3$ ,  $X_t = 1.3$ )

profit:

$$E[R]_{t+1} = E \left[ \frac{\partial \Pi}{\partial K} \right] = \frac{E[P]_{t+1}}{\mu} \frac{\partial Y}{\partial K}$$

where  $\mu = 1/(1 + 1/\eta)$  and  $\eta$  is the price elasticity of demand,  $\eta = \frac{\partial Y}{\partial P} \frac{P}{Y}$ .

Assuming a Cobb–Douglas production function  $Y_{t+1} = A_{t+1}K_{t+1}^{\alpha_k}L_{t+1}^{\alpha_l}$  we express the marginal product of capital  $\frac{\partial Y}{\partial K}$  as

$$E[R]_{t+1} = \frac{E[P]_{t+1}}{\mu} \frac{\alpha_k Y_{t+1}}{K} = \frac{\alpha_k}{\mu} \frac{E[S]_{t+1}}{K_{t+1}} = \frac{\alpha_k}{\mu} \left( \frac{E[S]_{t+1}}{K_{t+1}} \right) \quad (7)$$

where  $E[S]$  denotes expected sales in period  $t + 1$ . We assume rational expectations and replace expected sales at time  $t + 1$  with actual sales at time  $t + 1$  plus a firm-specific expectation error term,  $\nu_t$ , which is orthogonal to the information set available at the time when optimal cash holdings are chosen. Moreover, we allow for different profitability of capital across firms and industries, adding an industry specific term,  $\kappa$ , and a firm specific term,  $\omega$ . In linearized form we have<sup>13</sup>

$$E[\widehat{R}]_{t+1} = \theta \left( \frac{\widehat{S}_{t+1}}{TA_{t+1}} \right) + \kappa + \omega + \nu_t \quad (8)$$

The firm's initial resources are  $W_{t-1} = C_{t-1} + R_t I_{t-1} + \psi_{t-1}$ , where  $I_{t-1}$  is investment in period  $t - 1$ ,  $C_{t-1}$  is cash in the previous period,  $R_t$  is the gross return on investment in period  $t$  and  $\psi_{t-1}$  is the level of the cash flow shock most recently experienced by the firm. Hence, linearized initial resources are equal to

$$\widehat{W}_{t-1} = \zeta_1 \widehat{C}_{t-1} + \zeta_2 \widehat{I}_{t-1} + \zeta_3 \widehat{\psi}_{t-1} \quad (9)$$

---

<sup>13</sup>We proxy the firm's capital stock  $K$  with total assets,  $TA$ .

The interest rate on borrowing in the case when the firm does not have enough cash to cover a negative cash flow shock is taken to be proportional to the risk-free interest rate,  $TB_t$ :

$$\hat{X}_t = \delta TB_t \quad (10)$$

We employ macroeconomic uncertainty and idiosyncratic uncertainty as determinants of the bounds of the distribution of cash-flow shocks:

$$H_t = \beta_1^2 \tau_t^2 + \beta_2^2 \epsilon_t^2 + \beta_1 \beta_2 \text{cov}(\tau_t, \epsilon_t) \quad (11)$$

where  $\tau_t^2$  denotes a proxy for the degree of macroeconomic uncertainty while  $\epsilon_t^2$  is a measure of idiosyncratic uncertainty. Normalizing the covariance term (a second-order magnitude) to zero, the expression takes the form

$$\hat{H}_t = \beta_1^2 \hat{\tau}_t^2 + \beta_2^2 \hat{\epsilon}_t^2. \quad (12)$$

Finally, the probability of being able to acquire sufficient credit when threatened with bankruptcy,  $s_t$ , is parameterized as

$$\hat{s}_t = \gamma_1 LI_t + \gamma_2 E[\hat{R}]_{t+1} \quad (13)$$

where  $LI_t$  is the index of leading indicators: a measure of overall economic health.  $E[R]_{t+1}$  is the firm's expected return on investment. Both a stronger economic environment and a higher expected return on investment increase the firm's probability of acquiring sufficient credit if threatened with bankruptcy (see Altman (1968), Liu (2004)).

Substituting the parameterized expressions into equation (6) yields

$$\begin{aligned} \hat{C} &= \alpha_1 \zeta_1 \hat{C}_{t-1} + \alpha_1 \zeta_2 \hat{I}_{t-1} + \zeta_3 \hat{\psi}_{t-1} + (\alpha_2 + \alpha_5 \gamma_2) \theta \left( \frac{\widehat{S}}{TA} \right)_{t+1} + \alpha_3 \beta_1^2 \hat{\tau}_t^2 \\ &+ \alpha_3 \beta_2^2 \hat{\epsilon}_t^2 + \alpha_4 \delta TB_t + \alpha_5 \gamma_1 LI_t + (\alpha_2 + \alpha_5 \gamma_2) (\kappa + \omega + \nu). \end{aligned}$$

After normalization of cash holdings, debt and investment by total assets we derive our econometric model specification for firm  $i$  at time  $t$ :

$$\left(\frac{\widehat{C}_{it}}{\widehat{TA}_{it}}\right) = \phi_0 + \phi_1\left(\frac{\widehat{C}_{it-1}}{\widehat{TA}_{it-1}}\right) + \phi_2\left(\frac{\widehat{I}_{it-1}}{\widehat{TA}_{it-1}}\right) + \phi_3\left(\frac{\widehat{S}_{it+1}}{\widehat{TA}_{it+1}}\right) + \phi_4LI_{t-1} + \phi_5TB_{t-1} + \phi_6\hat{\psi}_{t-1} + \phi_7\hat{\epsilon}_{it}^2 + \phi_8\hat{\tau}_{t-1}^2 + \kappa' + \omega' + \nu'_{it} \quad (14)$$

where  $\phi_0 - \phi_8$  are complicated functions of the model's parameters and  $\hat{\epsilon}_{it}^2$ ,  $\hat{\tau}_{it-1}^2$  represent idiosyncratic and macroeconomic uncertainty, respectively. COMPUSTAT provides end-of-period values for firms, so that we use lagged proxies for macroeconomic variables in the regressions instead of contemporaneous proxies to be consistent with respect to the timing of events. Our first hypothesis—that macroeconomic uncertainty affects firms' cash holdings behavior—can be tested by investigating the significance of  $\phi_8$  in equation (14):

$$H_0 : \phi_8 = 0 \quad (15)$$

$$H_1 : \phi_8 \neq 0.$$

The second hypothesis relates to the role of idiosyncratic uncertainty on the optimal level of cash holdings. This hypothesis can be tested by investigating the significance of  $\phi_7$  in equation (14):

$$H_0 : \phi_7 = 0 \quad (16)$$

$$H_1 : \phi_7 \neq 0.$$

We expect that firms' managers will find it optimal to change their level of liquid asset holdings in response to variations of uncertainty about the macroeconomic environment. Hence, we should be able to reject  $H_0 : \phi_8 = 0$ .

Similarly, if an increase in idiosyncratic uncertainty causes an increase in cash holdings, the second hypothesis may be rejected as well.

## 2.4 Identification of macroeconomic uncertainty

The literature suggests various methods to obtain a proxy for macroeconomic uncertainty. In our investigation, as in Driver, Temple, and Urga (2005) and Byrne and Davis (2002), we use a GARCH model to proxy for macroeconomic uncertainty. We believe that this approach is more appropriate compared to alternatives such as proxies obtained from moving standard deviations of the macroeconomic series (e.g., Ghosal and Loungani (2000)) or survey-based measures based on the dispersion of forecasts (e.g., Graham and Harvey (2001), Schmukler, Mehrez, and Kaufmann (1999)). While the former approach suffers from substantial serial correlation problems in the constructed series the latter potentially contains sizable measurement errors.

In an environment of sticky wages and prices, unanticipated *volatility* of inflation will impose real costs on firms and their workers. In this context, we consider a volatility measure derived from changes in the consumer price index (CPI) as a proxy for the macro-level uncertainty that firms face in their financial and production decisions. We build a generalized ARCH (GARCH(1,1)) model for the series, where the mean equation is an autoregression, as described in Table 1. We find significant ARCH and GARCH coefficients. The conditional variances derived from this GARCH model are averaged to the quarterly frequency and then employed in the analysis as a measure of macroeconomic uncertainty,  $\hat{\tau}_t^2$ .

## 2.5 Identification of idiosyncratic uncertainty

One can employ different proxies to capture firm-specific risk. For instance, Bo and Lensink (2005) use three measures: stock price volatility, estimated as the difference between the highest and the lowest stock price normalized by the lowest price; volatility of sales measured by the coefficient of variation of sales over a seven-year window; and the volatility of number of employees estimated similarly to volatility of sales. Bo (2002) employs a slightly different approach, setting up the forecasting AR(1) equation for the underlying uncertainty variable driven by sales and interest rates. The unpredictable part of the fluctuations, the estimated residuals, are obtained from that equation and their three-year moving average standard deviation is computed. Kalckreuth (2000) uses cost and sales uncertainty measures, regressing operating costs on sales. The three-month aggregated orthogonal residuals from that regression are used as uncertainty measures.

Different from the studies cited above, we proxy the idiosyncratic uncertainty by computing the standard deviation of the closing price for the firm's shares over the last nine months.<sup>14</sup> This measure is calculated using COMPUSTAT items *data12*, 1st month of quarter close price; *data13*, 2nd month of quarter close price; *data14*, 3rd month of quarter close price and their first and second lags. We believe that volatility of stock prices reflect not only sales or cost uncertainty but also captures other idiosyncratic risks.

---

<sup>14</sup>To check the robustness of our results to the period considered, we also used the standard deviation of closing price over the last six months; we receive quantitatively similar results.

To ascertain that the measure captured by this method is different from that used to proxy macroeconomic uncertainty described in Section 2.4, we compute the correlation between the two measures. We find a very low correlation (-0.001) between idiosyncratic uncertainty and the macroeconomic uncertainty measure.

## 3 Empirical Implementation

### 3.1 Data construction

For the empirical investigation we work with Standard & Poor's Quarterly Industrial COMPUSTAT database of U.S. firms. The initial database includes 201,552 firm-quarter characteristics over 1993–2002. We restrict our analysis to manufacturing companies for which COMPUSTAT provides information. The firms are classified by two-digit Standard Industrial Classification (SIC). The main advantage of the dataset is that it contains detailed balance sheet information.

In order to construct firm-specific variables we utilize COMPUSTAT data items Cash and Short-term Investment (*data1* item) and Total Assets (*data6* item), Capital Expenditures (*data90* item), Sales (*data2* item) for liquidity ratio ( $Cash/TA$ ), Investment-to-Asset ratio ( $I/TA$ ) and Sales-to-Asset ratio ( $S/TA$ ). A measure of cash-flow shocks,  $\psi$ , is calculated as the first difference of the cash flow/total assets ratio.<sup>15</sup>

---

<sup>15</sup>Cash flow is defined as sum of depreciation (*data5*) and income before extraordinary items (*data8*).

We apply several sample selection criteria to the original sample. The following observations are set as missing values in our estimation sample: (a) negative values for cash-to-assets, leverage, sales-to-assets and investment-to-assets ratios; (b) the values of ratio variables lower than the first percentile or higher than the 99th percentile; (c) those from firms that have fewer than ten observations over the time span. We employ the screened data to reduce the potential impact of outliers upon the parameter estimates. After the screening and including only manufacturing sector firms we obtain on average 700 firms' quarterly characteristics.<sup>16</sup>

Descriptive statistics for the quarterly means of cash-to-asset ratios along with investment and sales to asset ratios and  $\psi$  are presented in Table 2. From the means of the sample we see that firms hold about 10 percent of their total assets in cash. This amount is sizable and similar to that reported in Baum, Caglayan, Ozkan, and Talavera (2006).

The empirical literature investigating firms' cash-holding behavior has identified that firm-specific characteristics play an important role.<sup>17</sup> We might expect that a group of firms with similar characteristics (e.g., those firms with high levels of leverage) might behave similarly, and quite differently from those with differing characteristics. Consequently, we split the sample into subsamples of firms to investigate if the model's predictions would receive support in each subsample. We consider five different sample splits in the interest of identifying groups of firms that may have similar

---

<sup>16</sup>We also use winsorized versions of balance sheet measures and receive similar quantitative results.

<sup>17</sup>See Ozkan and Ozkan (2004).



characteristics relevant to their choice of liquidity. The splits are based on firm size, durable-goods vs. non-durable goods producers, growth rate, investment rate, and leverage ratio. The durable/non-durable classifications only apply to firms in the manufacturing sector (one-digit SIC 2 or 3). A firm is considered durable if its primary SIC is 24, 25, 32–39.<sup>18</sup> SIC classifications for non-durable industries are 20–23 or 26–31.<sup>19</sup> All other sample splits are based on firms' average values of the characteristic lying in the first or fourth quartile of the sample. For instance, a firm with average total assets above the 75%th percentile of the distribution will be classed as large, while a firm with average total assets below the 25%th percentile will be classed as small. As such, the classifications are not mutually exhaustive.

The detrended index of leading indicators ( $LI_t$ ) is computed from DRI–McGraw Hill Basic Economics series DLEAD. The interest rate,  $TB_t$  is the three-month secondary market Treasury bill rate obtained from the same database (item *FYGM3*).<sup>20</sup>

---

<sup>18</sup>These industries include lumber and wood products, furniture, stone, clay, and glass products, primary and fabricated metal products, industrial machinery, electronic equipment, transportation equipment, instruments, and miscellaneous manufacturing industries.

<sup>19</sup>These industries include food, tobacco, textiles, apparel, paper products, printing and publishing, chemicals, petroleum and coal products, rubber and plastics, and leather products makers.

<sup>20</sup>Further details on the data used are presented in Appendix A.

## 3.2 Empirical results

Estimates of optimal corporate behavior often suffer from endogeneity problems, and the use of instrumental variables may be considered as a possible solution. We estimate our econometric models using the system dynamic panel data (DPD) estimator. DPD combines equations in differences of the variables with equations in levels of the variables. In this “system GMM” approach (see Blundell and Bond (1998)), lagged levels are used as instruments for differenced equations and lagged differences are used as instruments for level equations. The models are estimated using a first difference transformation to remove the individual firm effect.

The reliability of our econometric methodology depends crucially on the validity of instruments. We check it with Sargan’s test of overidentifying restrictions, which is asymptotically distributed as  $\chi^2$  in the number of restrictions. The consistency of estimates also depends on the serial correlation in the error terms. We present test statistics for first-order and second-order serial correlation in Tables 3–5, which lay out our results on the links between macroeconomic uncertainty, idiosyncratic uncertainty and the liquidity ratio. For the “all firms” sample, we also present the full set of coefficients corresponding to the  $\alpha$  parameters of equation (14). In the interest of brevity, we only present the coefficients on the uncertainty variables, corresponding to equations (15) and (16) for the subsample splits.<sup>21</sup>

Table 3 displays results the Blundell–Bond one-step system GMM estimator with the conditional variance of CPI inflation as a proxy for macroe-

---

<sup>21</sup>Full results are available on request.

conomic uncertainty. An increase in macroeconomic uncertainty leads to an increase in firms' cash holdings, with a highly significant effect. Idiosyncratic uncertainty is also important, with a significant positive coefficient estimate. Hence, our findings support the hypotheses that heightened levels of macroeconomic and idiosyncratic uncertainty lead to a rise in the firm's liquidity ratio. The results also suggest significant positive persistence in the liquidity ratio with a coefficient of 0.7846. A negative and significant effect of the expected sales-to-assets ratio is also in accordance with our expectations. This ratio may be considered as a proxy for the firm's expected return on investment. When the expected opportunity cost of holding cash increases, firms are likely to decrease their liquidity ratio. Improvements in the state of the macroeconomy (proxied by the index of leading indicators) or increases in the cost of funds (via the Treasury bill rate) will reduce the firm's demand for cash.<sup>22</sup> Overall the data for this broadest sample support the basic predictions of the model that we laid out in section 2.

### **3.3 Results for subsamples of firms**

Having established the presence of a positive role for macroeconomic uncertainty on firm's cash holdings, we next investigate if the strength of the association varies across groups of firms with differing characteristics. It is important to consider that the average cash-to-asset ratios of firms with dif-

---

<sup>22</sup>Although the analytical model predicts that the Treasury bill rate should be positively related to the liquidity ratio, the model assumes that the firm cannot lend, thus ignoring the opportunity cost of cash holdings.

ferent characteristics vary widely. The last lines of Tables 4 and 5 present the sample average liquidity ratios ( $\mu_{C/TA}$ ) for each subsample. On average, small firms hold twice as much cash as do their large counterparts, perhaps reflecting that they have constrained access to external funds. Durable-goods makers hold slightly more cash, on average than do non-durable goods makers. High-growth firms hold significantly more cash than low-growth counterparts, perhaps reflecting their greater cash flow needs. High-investment firms, who perhaps economize on cash holdings in order to finance capital expenditures, hold less cash on average than firms in the lowest quartile of the investment rate distribution. High-leverage firms also economize on cash, holding only about one-quarter as much as than low-leverage counterparts. The variations in subsample average liquidity ratios will naturally influence those firms' sensitivity to macroeconomic and idiosyncratic uncertainty.

The first two columns of Table 4 reports results for small and large firms. Based on the point estimates, the former firms are highly sensitive to the changes in volatility of CPI inflation, with large firms display a considerably smaller sensitivity. Small firms also have a much larger coefficient for idiosyncratic uncertainty. The greater sensitivity of small firms could be explained by the fact that smaller firms are more likely to be financially constrained. As Almeida, Campello, and Weisbach (2004) indicate, financially unconstrained firms have no precautionary motive to hold cash; their cash holding policies are indeterminate. In contrast, for financially constrained firms, any change in the level of uncertainty that affects managers' ability to predict cash flows should cause them to alter their demand for liquidity. We see that small firms are much more sensitive to both forms of uncertainty, and hold much

more cash on average than do large firms.

We find an interesting contrast in the results for durable goods makers and non-durable goods makers, reported in columns 3 and 4. While both categories of firms exhibit positive and significant effects for macroeconomic uncertainty, durable goods makers also exhibit sensitivity to idiosyncratic uncertainty, which appears to have no significant effect on non-durable goods firms. Durable goods makers' production involves greater time lags and larger inventories of work-in-progress, which may imply a greater need for cash as well as a greater sensitivity to uncertainty.

The last two columns report results for high-growth and low-growth firms, respectively. Here again, high-growth firms display sensitivity to idiosyncratic uncertainty, unlike their low-growth counterparts. Both types of firms display significant sensitivity to macroeconomic uncertainty, with larger effects for the low-growth category. This may reflect the smaller levels of cash held by those firms.

The first two columns of Table 5 present results for high-investment firms: those in the top quartile of investment-to-assets ratios versus their low-investment counterparts. Idiosyncratic uncertainty has no effect on low-investment firms, while these firms display considerably greater sensitivity to macroeconomic uncertainty than their high-investment counterparts. Firms in the latter group are meaningfully affected by both types of uncertainty.

The last two columns of Table 5 present results for firms with high leverage versus low leverage, respectively. Both types of firms are significantly affected by both macroeconomic uncertainty and idiosyncratic uncertainty. The effects of macroeconomic uncertainty are considerably stronger for the

low-leverage firms, who as noted hold almost four times as much cash, on average, as do highly-levered firms. Both types of firms are sensitive to idiosyncratic uncertainty, with high-leverage firms displaying almost twice as much sensitivity.

In summary, we may draw several conclusions from the analysis of these five subsamples. Variations in idiosyncratic uncertainty have a strong effect on the liquidity ratios of small firms, durable-goods makers, and firms experiencing high growth, high investment or high leverage. Variations in macroeconomic uncertainty have significant effects on liquidity of all ten subsamples, but those effects differ considerably in strength across subsamples. The subsample evidence buttresses our findings from the “all firms” full sample and further strengthens support for the hypotheses generated by our analytical model.

## 4 Conclusions

We set out in this paper to shed light on the link between the level of liquidity of manufacturing firms and uncertainty measures. Based on the theoretical predictions obtained from a simple optimization problem, we first show that firms will increase their level of cash holdings when macroeconomic or idiosyncratic uncertainty increases. This result confirms the existence of a *precautionary motive* for holding liquid assets among non-financial firms. Next we empirically investigate if our model receives support from a large firm-level dataset of U.S. non-financial firms from Quarterly COMPUSTAT over the 1993–2002 period using dynamic panel data methodology. The results

suggest positive and significant effects of both macroeconomic and idiosyncratic uncertainty on firms' cash holding behavior, supporting the hypotheses of equations (15) and (16). We find that firms unambiguously increase their liquidity ratio in more uncertain times. The strength of their response differs meaningfully across subsamples of firms with similar characteristics. When the macroeconomic environment is less predictable, or when idiosyncratic risk is higher, companies become more cautious and increase their liquidity ratio.

Our results should be considered in conjunction with those of Baum, Caglayan, Ozkan, and Talavera (2006) who predict that during periods of higher uncertainty firms behave more similarly in terms of their cash-to-asset ratios. Taken together, these studies allow us to conjecture that as either macroeconomic or idiosyncratic uncertainty increases the total amount of cash held by non-financial firms will increase significantly, with negative effects on the economy. The idea behind this proposition is that cash hoarded but not applied to potential investment projects can keep the economy lingering in a recessionary phase. Since during recessionary periods firms generally are more sensitive to asymmetric information problems, cash hoarding will exacerbate these problems and delay an economic recovery.

## References

- Almeida, Heitor, Murillo Campello, and Michael Weisbach, 2004, The cash flow sensitivity of cash, *Journal of Finance* 59, 1777–1804.
- Altman, E., 1968, Financial ratios discriminant analysis and prediction of corporate bankruptcy, *Journal of Finance* pp. 261–280.
- Baum, Christopher F., Mustafa Caglayan, Neslihan Ozkan, and Oleksandr Talavera, 2006, The impact of macroeconomic uncertainty on non-financial firms' demand for liquidity, *Review of Financial Economics*.
- Blundell, Richard, and Stephen Bond, 1998, Initial conditions and moment restrictions in dynamic panel data models, *Journal of Econometrics* 87, 115–143.
- Bo, Hong, 2002, Idiosyncratic uncertainty and firm investment, *Australian Economic Papers* 41, 1–14.
- , and Robert Lensink, 2005, Is the investment-uncertainty relationship nonlinear? an empirical analysis for the Netherlands, *Economica* 72, 307–331.
- Bruinshoofd, W.A., 2003, Corporate investment and financing constraints: Connections with cash management, WO Research Memoranda (discontinued) 734 Netherlands Central Bank, Research Department.
- Byrne, Joseph P., and E. Philip Davis, 2002, Investment and uncertainty in the G7, Discussion papers National Institute of Economic Research, London.



- Driver, Ciaran, Paul Temple, and Giovanni Urga, 2005, Profitability, capacity, and uncertainty: a model of UK manufacturing investment, *Oxford Economic Papers* 57, 120–141.
- Ghosal, Vivek, and Prakash Loungani, 2000, The differential impact of uncertainty on investment in small and large business, *The Review of Economics and Statistics* 82, 338–349.
- Graham, John R., and Campbell R. Harvey, 2001, Expectations of equity risk premia, volatility and asymmetry from a corporate finance perspective, NBER Working Papers 8678 National Bureau of Economic Research, Inc.
- Harford, J., 1999, Corporate cash reserves and acquisitions, *Journal of Finance* 54, 1967–1997.
- Kalckreuth, Ulf, 2000, Exploring the role of uncertainty for corporate investment decisions in Germany, Discussion Papers 5/00 Deutsche Bundesbank - Economic Research Centre.
- Keynes, John Maynard, 1936, *The general theory of employment, interest and money* (London: Harcourt Brace).
- Kim, Chang-Soo, David C. Mauer, and Ann E. Sherman, 1998, The determinants of corporate liquidity: Theory and evidence, *Journal of Financial and Quantitative Analysis* 33, 335–359.
- Liu, Jia, 2004, Macroeconomic determinants of corporate failures: evidence from the UK, *Applied Economics* 36, 939–945.

- Mills, Karen, Steven Morling, and Warren Tease, 1994, The influence of financial factors on corporate investment, RBA Research Discussion Papers rdp9402 Reserve Bank of Australia.
- Modigliani, F., and M. Miller, 1958, The cost of capital, corporate finance, and the theory of investment, *American Economic Review* 48, 261–297.
- Myers, Stewart C., and Nicholas S. Majluf, 1984, Corporate financing and investment decisions when firms have information that investors do not have, *Journal of Financial Economics* 13, 187–221.
- Opler, Tim, Lee Pinkowitz, Rene Stulz, and Rohan Williamson, 1999, The determinants and implications of cash holdings, *Journal of Financial Economics* 52, 3–46.
- Ozkan, Aydin, and Neslihan Ozkan, 2004, Corporate cash holdings: An empirical investigation of UK companies, *Journal of Banking and Finance* 28, 2103–2134.
- Schmukler, Sergio, Gil Mehrez, and Daniel Kaufmann, 1999, Predicting currency fluctuations and crises - do resident firms have an informational advantage?, Policy Research Working Paper Series 2259 The World Bank.

## Appendix A. Construction of macroeconomic and firm specific measures

The following variables are used in the empirical study.

*From the Quarterly Industrial COMPUSTAT database:*

DATA1: Cash and Short-Term Investments

DATA2: Sales

DATA5: Depreciation

DATA6: Total Assets

DATA8: Income before extraordinary items

DATA12: 1st month of quarter close price

DATA13: 2nd month of quarter close price

DATA14: 3rd month of quarter close price

DATA90: Capital Expenditures

*From International Financial Statistics:*

64IZF: Industrial Production monthly

*From the DRI-McGraw Hill Basic Economics database:*

DLEAD: index of leading indicators

FYGM3: Three-month U.S. Treasury bill interest rate

Appendix B. Geometry of Cash-Holding shock

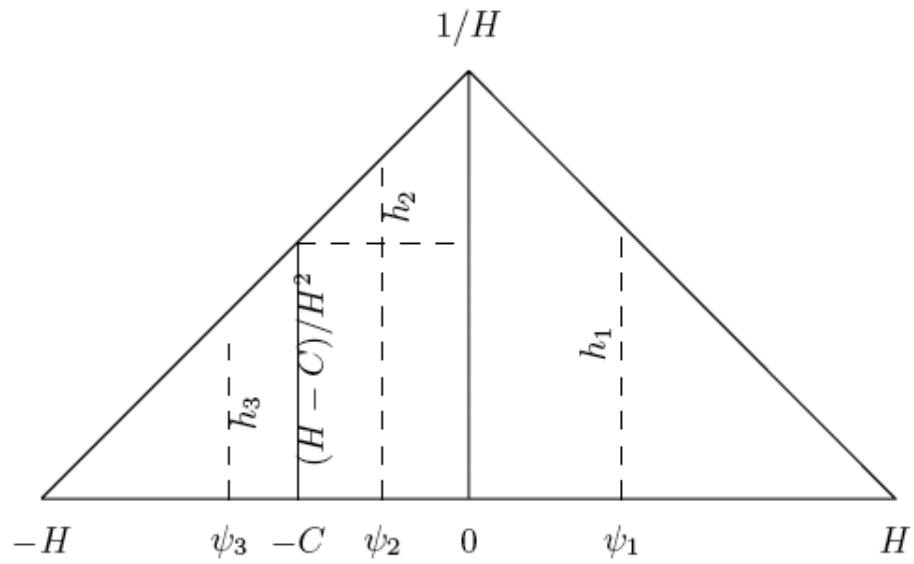

Table 1: GARCH proxy for macroeconomic uncertainty

<i>CPI Inflation</i>	
Lagged dep.var.	0.989 (0.00)***
Constant	0.000 (0.00)
AR(1)	0.285 (0.04)***
ARCH(1)	0.089 (0.02)***
GARCH(1)	0.872 (0.03)***
Constant	0.000 (0.00)***
Log-likelihood	2809.59
Observations	641

Note: OPG standard errors in parentheses. \*\*\* significant at 1%

Table 2: Descriptive Statistics, 1993Q1–2002Q4

All firms	$\mu$	$\sigma^2$	$p25$	$p50$	$p75$	$N$
$C/TA_t$	0.1045	0.1379	0.0150	0.0452	0.1395	29,949
$I/TA_t$	0.0348	0.0335	0.0120	0.0249	0.0464	29,843
$S/TA_t$	0.2943	0.1467	0.1998	0.2729	0.3627	30,355
$\psi_t$	0.0003	0.0227	-0.0057	0.0009	0.0069	25,180
$\epsilon_t^2$	0.0270	0.0279	0.0095	0.0190	0.0342	32,012
$\tau_{CPI,t}^2$	0.0206	0.0083	0.0145	0.0165	0.0291	32,800

Note:  $p25$ ,  $p50$  and  $p75$  represent the quartiles of the distribution,  $N$  is sample size (number of firm-quarters), while  $\mu$  and  $\sigma^2$  represent its mean and variance respectively.

Table 3: Determinants of Corporate Liquidity: All Firms

Dependent variable: $C/TA_t$	
$C/TA_{t-1}$	0.7846*** [0.024]
$I/TA_{t-1}$	-0.0405*** [0.013]
$S/TA_{t+1}$	-0.0353*** [0.007]
$\psi_{t-1}$	0.0885*** [0.028]
$\epsilon_{it}^2$	0.0876*** [0.024]
$LI_{t-1}$	-0.0010*** [0.000]
$TB_{t-1}$	-0.0012*** [0.000]
$\tau_{CPI,t-1}^2$	0.2567*** [0.067]
Sargan	0.38
AR(1)	-12.12***
AR(2)	1.39
$N$	21,276

Note: The equation includes constant and industry dummy variables. Asymptotic robust standard errors are reported in the brackets. Estimation by System GMM using the DPD package for Ox. Sargan is a Sargan-Hansen test of overidentifying restrictions (p-value reported). AR(k) is the test for  $k$ -th order autocorrelation. Instruments for System GMM estimations are  $B/K_{t-3}$  to  $B/TA_{t-5}$ ,  $CASH/TA_{t-2}$  to  $CASH/TA_{t-5}$ ,  $I/TA_{t-2}$  to  $I/TA_{t-5}$ ,  $S/TA_{t-2}$  to  $S/TA_{t-5}$  and  $\Delta S/TA_{t-1}$ ,  $\Delta CASH/TA_{t-1}$ , and  $\Delta I/TA_{t-1}$ . \* significant at 10%; \*\* significant at 5%; \*\*\* significant at 1%.

Table 4: Determinants of Corporate Liquidity: Sample splits I

Dependent variable: $C/TA_t$						
	Small firms	Large firms	Durable manufacturers	Non-durable manufacturers	High growth	Low growth
$\epsilon_{it}^2$	0.2774*** [0.086]	0.1196*** [0.040]	0.1060*** [0.028]	0.0363 [0.032]	0.1477*** [0.039]	0.0412 [0.082]
$\tau_{CPI,t-1}^2$	0.3662*** [0.113]	0.1661** [0.078]	0.2774*** [0.060]	0.2394*** [0.062]	0.2084* [0.109]	0.3083*** [0.098]
Sargan	1.00	1.00	0.18	0.99	1.00	1.00
AR(1)	-7.19***	-6.35***	-9.57***	-8.06***	-7.93***	-5.77***
AR(2)	0.94	1.19	0.85	1.19	0.72	0.94
$N$	4,557	4,842	12,517	8,759	4,795	4,465
$\mu_{C/TA}$	0.1487	0.0783	0.1145	0.0903	0.1530	0.1062

Note: Every equation includes constant,  $\psi_{i,t-1}$ ,  $S/TA_{i,t+1}$ ,  $I/TA_{i,t-1}$ ,  $C/TA_{t-1}$ ,  $LI_{t-1}$ ,  $TB_{t-1}$  and industry dummy variables. Asymptotic robust standard errors are reported in the brackets. Estimation by System GMM using the DPD package for Ox. \* significant at 10%; \*\* significant at 5%; \*\*\* significant at 1%.



Table 5: Determinants of Corporate Liquidity: Sample splits II

Dependent variable: $C/TA_t$				
	High	Low	High	Low
	investment	investment	leverage	leverage
$\epsilon_{it}^2$	0.1075*** [0.036]	-0.0052 [0.047]	0.1295** [0.061]	0.0622* [0.035]
$\tau_{CPI,t-1}^2$	0.1941** [0.093]	0.3921*** [ 0.105]	0.1665** [0.072]	0.2891*** [0.097]
Sargan	1.00	1.00	1.00	1.00
AR(1)	-5.71***	-7.03***	-4.46***	-8.34***
AR(2)	1.63	-0.09	0.53	1.62
$N$	4,940	4,879	4,132	5,430
$\mu_{C/TA}$	0.1077	0.1262	0.0573	0.1928

Note: Every equation includes constant,  $\psi_{i,t-1}$ ,  $S/TA_{i,t+1}$ ,  $I/TA_{i,t-1}$ ,  $C/TA_{t-1}$ ,  $LI_{t-1}$ ,  $TB_{t-1}$  and industry dummy variables. Asymptotic robust standard errors are reported in the brackets. Estimation by System GMM using the DPD package for Ox. \* significant at 10%; \*\* significant at 5%; \*\*\* significant at 1%.